

Hinge systems



- ▶ CLIP top BLUMOTION | CLIP top – hinges
- ▶▶ Blind corner application

Hinge systems

Blind corner hinge inset application

Webcode
DQDK7Y



- Hinge for **blind corner applications**
- **CLIP top BLUMOTION** with integrated **BLUMOTION** (with deactivation option)
- **CLIP top** without closing mechanism (spring)
- 95° | 83° opening angle
- 3-dimensional front adjustment
- Convenient spiral-tech depth adjustment
- Tool-free door to cabinet assembly and removal
- With **INSERTA** tool-free hinge to door assembly

Application

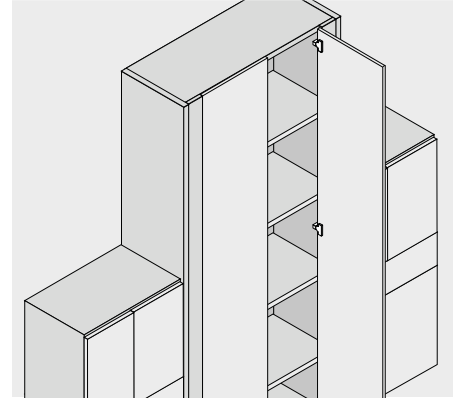

Order information

Inset application 95° opening angle



Boss		INSERTA		
Hinge	Spring	Colour		Part no.
CLIP top BLUMOTION	●	NI ONS		79B9590
● With spring		NI	Nickel plated	
○ Unsprung		ONS	Onyx black	

Inset application 83° opening angle



Boss		Screw-on		
Hinge	Spring	Colour		Part no.
CLIP top BLUMOTION	●	NI		☎ 79B9550.83
CLIP top	○	NI		☎ 78T9550.83

Boss		Knock-in		
Hinge	Spring	Colour		Part no.
CLIP top BLUMOTION	●	NI ONS		79B9580

Accessories

Hinge arm cover cap			
Print Stamp	Logo	Colour	Part no.
Plain	–	NI ONS	70.1503
Stamped	Blum	NI ONS	70.1503.BP

Note

CLIP top BLUMOTION and CLIP top hinges cannot be combined with each other on a door.

Accessories – general

TIP-ON for doors		
Version	Spring	Part no.
Short version	○	956.1004
Extended version	○	956A1004
Extended version	●	956A1006
● With spring	○ Unsprung	

Hinge boss cover cap		
Hinge	Colour	Part no.
CLIP top BLUMOTION	NI ONS	70T3504
CLIP top	NI	70T1504
NI Nickel plated	ONS Onyx black	

Chipboard screws		
Ø (mm)	Length (mm)	Part no.
3.5	15	609.1500
3.5	17	609.1700

Insertion ram		
Colour	Material	Part no.
Orange	Nylon	MZM.0040

Blind corner hinge inset application

Webcode
DQDK7Y

Planning

Hinge dimensions and gap calculation based on factory setting (mounting plate spacing = 3 mm)

Hinge and front protrusion at full opening angle

Inset application

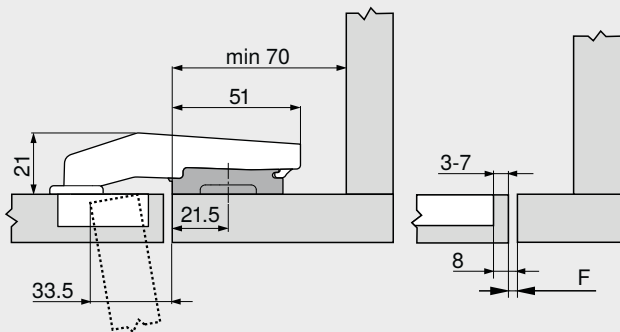

Move standard mounting plate fixing positions 15.5 mm nearer the edge of the muntin (i.e. set back by 21.5 mm)!
Use 3 mm spaced standard mounting plates only to ensure door and muntin are flush on the inside!
F = 8 mm – TB
F Gap
TB Drilling distance

Minimum gap F for fronts with a front radius (R = 1 mm) based on the factory setting

Drilling distance TB (mm)	Front thickness FD (mm)											
	16	18	19	20	22	24	26	28	29	30	31	32
3	0.2	0.3	0.4	0.5	0.8	1.0	1.5	1.9	Δ	Δ	Δ	Δ
4	0.2	0.3	0.4	0.5	0.7	1.0	1.4	1.8	Δ	Δ	Δ	Δ
5	0.2	0.3	0.4	0.5	0.7	1.0	1.4	1.8	Δ	Δ	Δ	Δ
6	0.2	0.3	0.4	0.5	0.7	1.0	1.4	1.8	Δ	Δ	Δ	Δ
7	0.2	0.3	0.4	0.5	0.7	0.9	1.4	1.7	Δ	Δ	Δ	Δ

Δ In these cases a trial is recommended

Adjustment

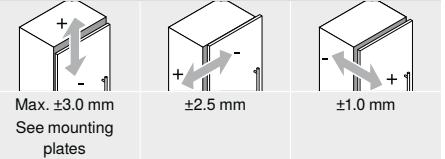

Screw-on

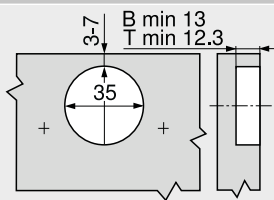

B CLIP top BLUMOTION
T CLIP top

INSERTA | knock-in

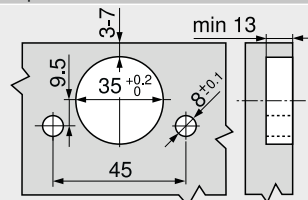

Hinge boss dimensions

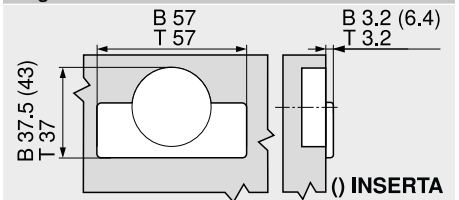

B CLIP top BLUMOTION
T CLIP top

Page instructions

Overview – CLIP top BLUMOTION CLIP top – hinges	75
Mounting plates	156
Accessories – hinge arm cover cap	164
Accessories – general	166
Overview – BLUMOTION for doors	171

Overview – TIP-ON for doors	185
Overview – assembly devices	561
More technical details	662

Assembly, removal and adjustment

Short-URL
www.blum.com/a210

